

DATASHEET

# Petrosa

SR43W081 • lamiiANT®

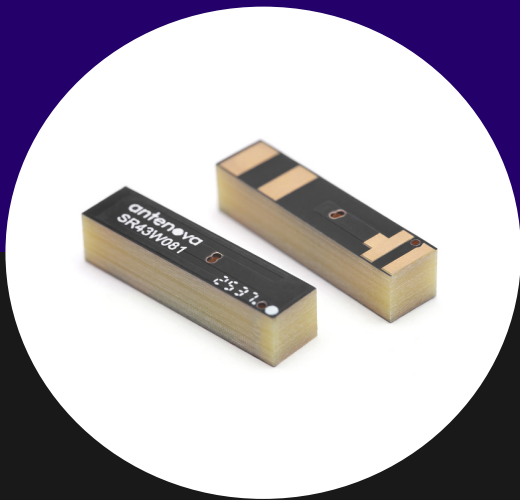

## Features

- Wi-Fi6E and Wi-Fi7 : 802.11a/b/g/n/ac/ax
- Antenna for 2.4 – 2.5 GHz and 4.9-7.125 GHz applications
- Works on a ground plane. No clearance required.
- Ideal for products that require high data rates such as video cameras.
- High performance: DFI (Designed For Integration)
- Small SMD footprint of 20mm × 5mm
- Supplied on Tape and Reel

# 1. Description

---

Petrosa is compatible with Wi-Fi6E & Wi-Fi7 protocols, and also supports older versions of WiFi on 2.4 and 5GHz bands. It operates over a ground plane and integrates with minimal PCB clearance area. Recommended matching network component values are given to speed up the design integration. Petrosa is ideal for single and MIMO antenna systems.

# 2. Applications

---

- Portable/ Wearable Devices
- Access Points/Network Devices
- PC-cards/ Games consoles
- Immersive VR/AR & Telemedicine
- High-Definition video/Set-Top-Boxes
- MIMO Systems

# 3. Part number

---

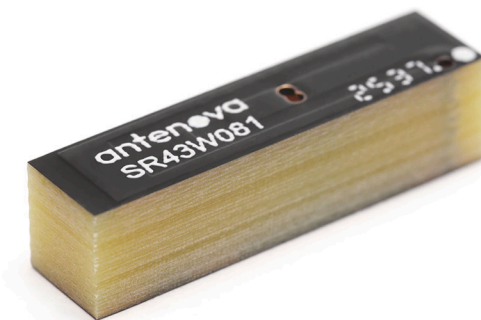

## 4. General data

---

Frequency	2400-2500MHz 4900-7125MHz
Polarization	Linear
Operating temperature	-40°C to 140°C
Environmental condition test	ISO16750-4 5.1.1.1/5.1.2.1/5.3.2
Impedance with matching	50 $\Omega$
Weight	<1.5g
Antenna type	SMD
Dimensions	20.0 x 5.0 x 5.0 (mm)

## 5. RF characteristics

---

Frequency	2400- 2500 MHz	4900 - 7125 MHz
Peak gain	2.3dBi	4.0dBi
Average gain (Linear)	-2.6 dB	-3.5 dB
Average efficiency	55.0 %	45.0 %
Average efficiency	-7.8dB	-4.1dB
Maximum VSWR	2.3:1	4.3:1

All data measured on Antenna's evaluation PCB Part No. SR43W081-EVB-1

## 6. RF performance

### 6.1. Return loss

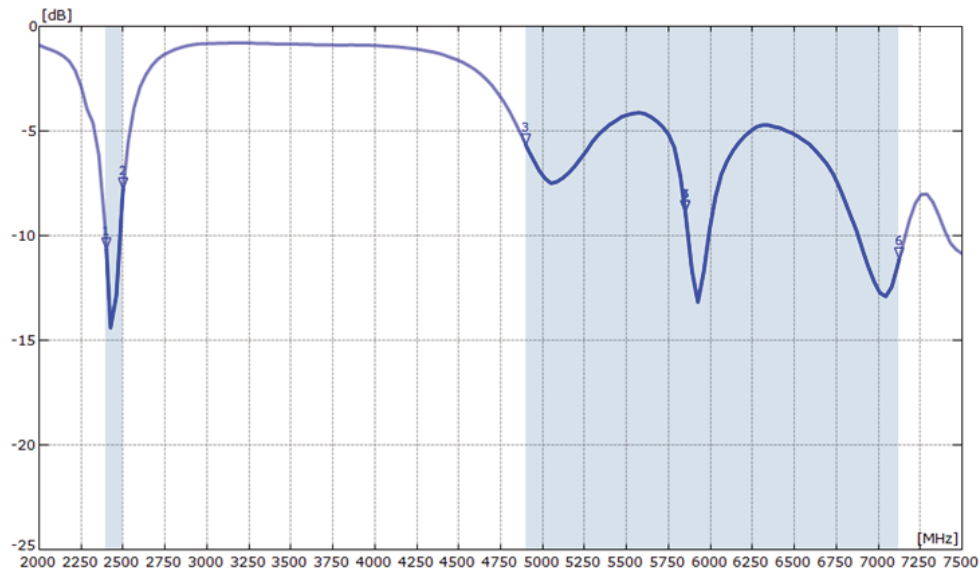

All data measured on Antenova's evaluation PCB Part No. SR43W081-EVB-1

### 6.2. VSWR

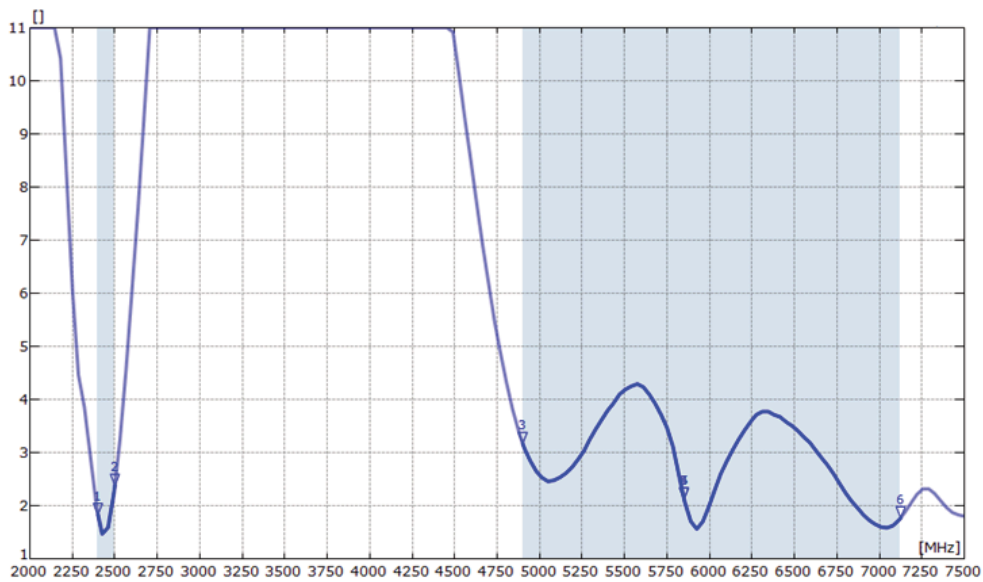

All data measured on Antenova's evaluation PCB Part No. SR43W081-EVB-1

### 6.3. Efficiency

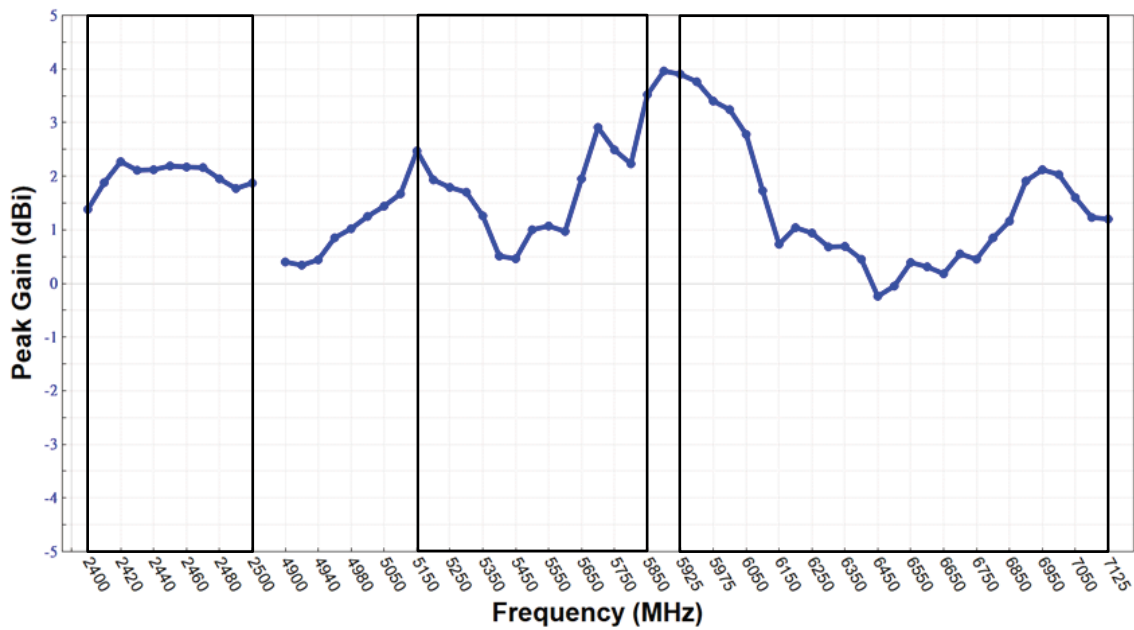
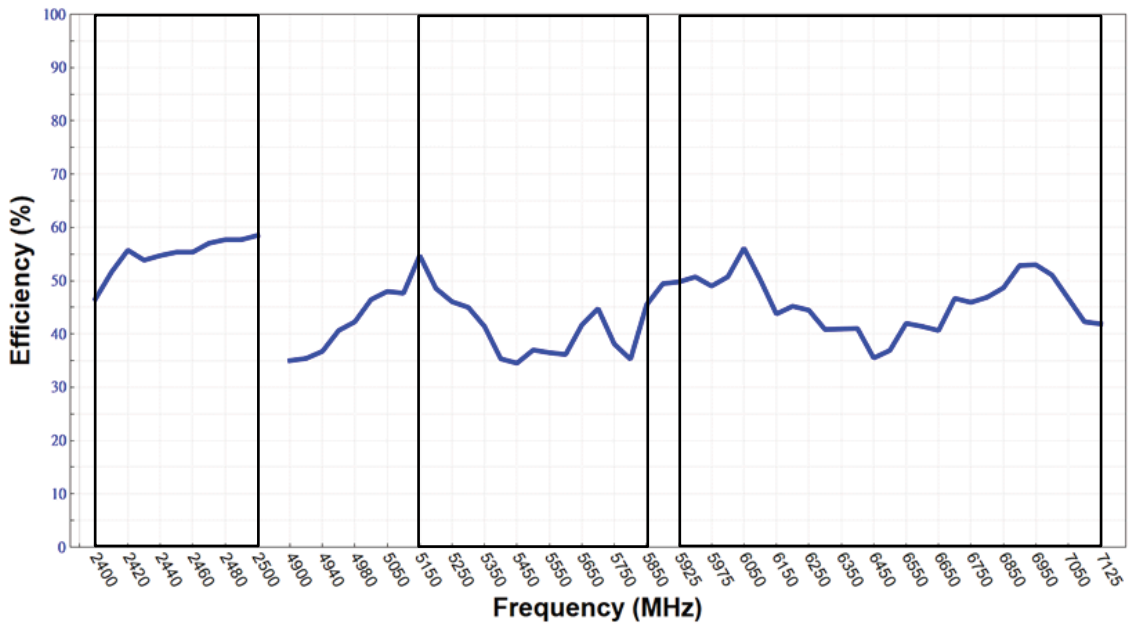

All data measured on Antenna's evaluation PCB Part No. SR43W081-EVB-1

# 6.4. Antenna pattern

## 6.4.1. 2450MHZ

3D pattern at 2450MHz

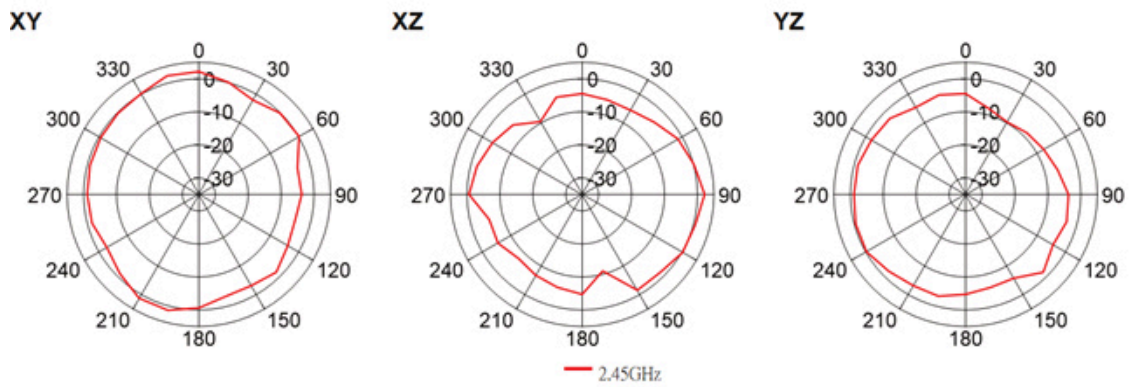
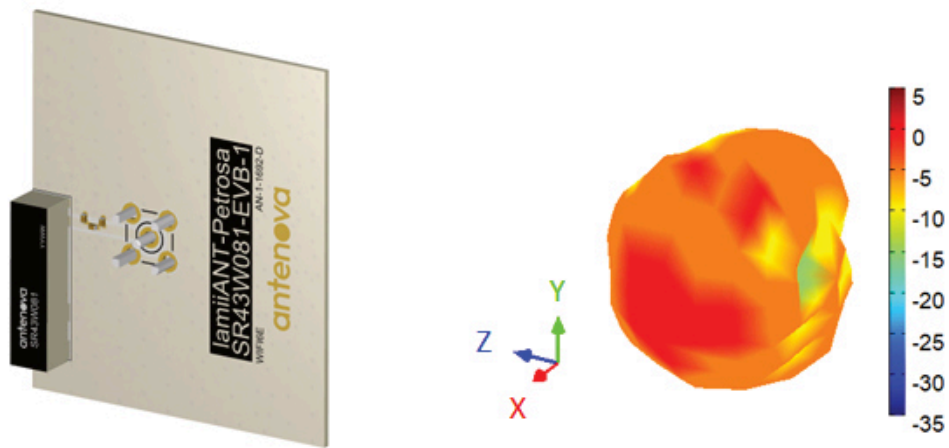

### 6.4.2. 4900MHZ

3D pattern at 4900MHZ MHz

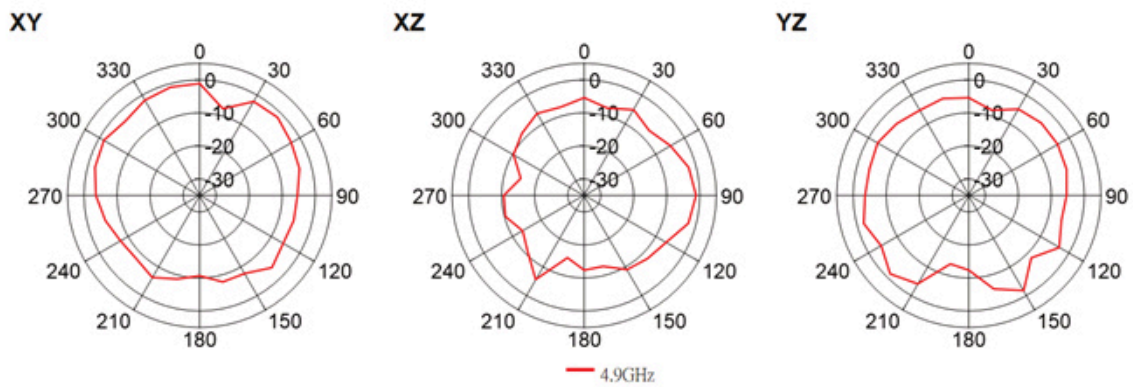
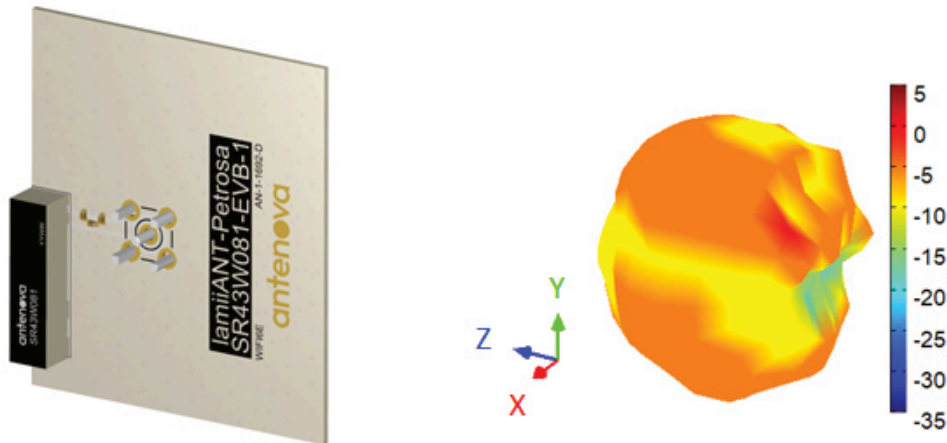

### 6.4.3. 5500MHZ

3D pattern at 5500MHz

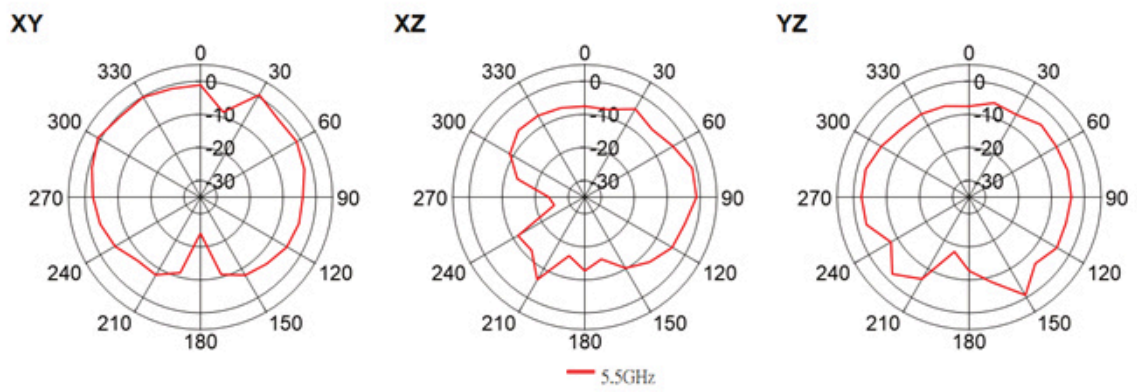
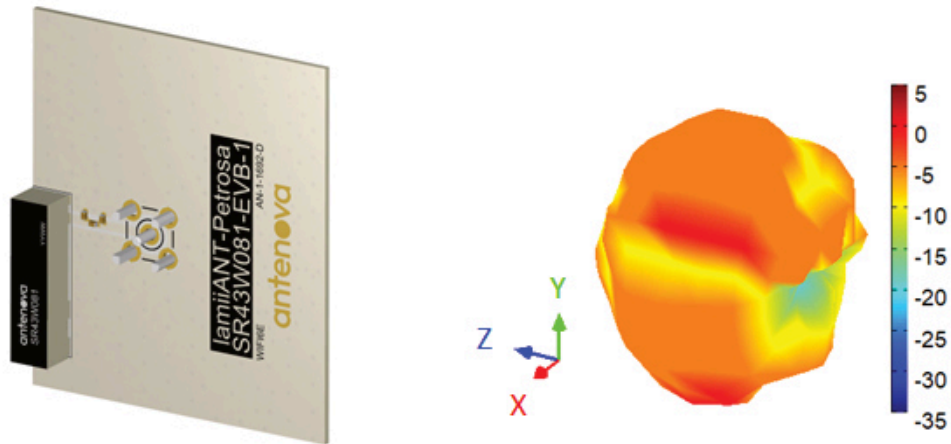

### 6.4.4. 6500MHZ

3D pattern at 6500MHz

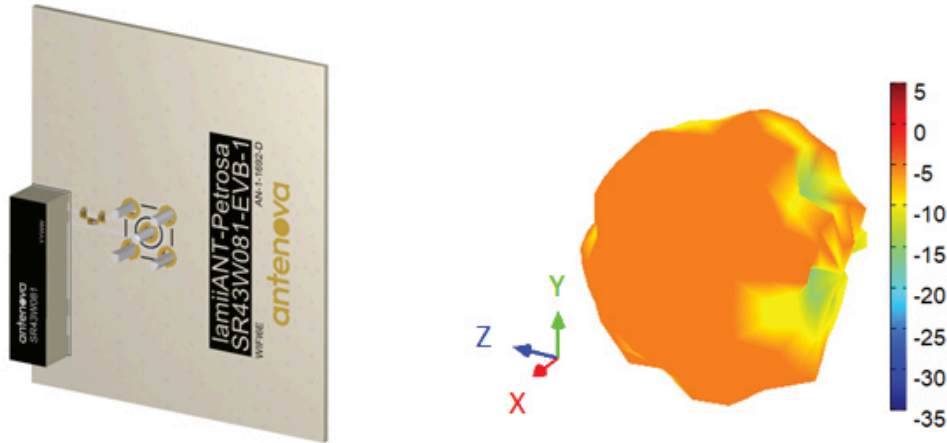

XY

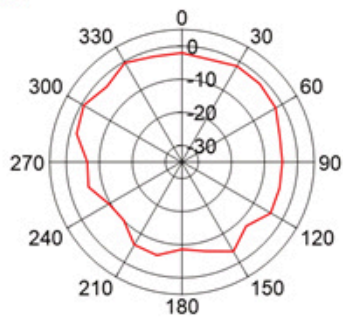

XZ

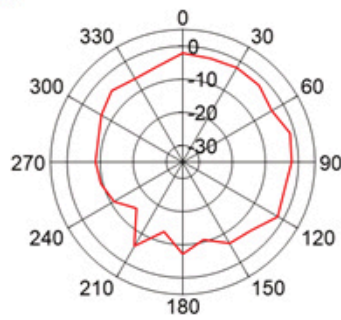

YZ

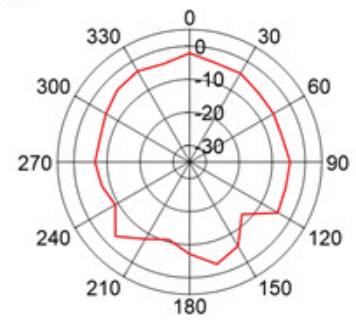

— 6.5GHz

### 6.4.5. 7125MHZ

3D pattern at 7125MHz

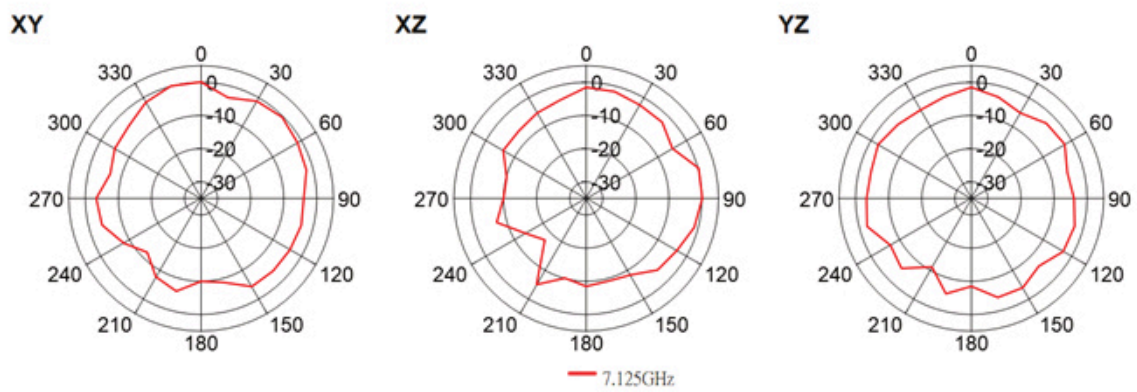
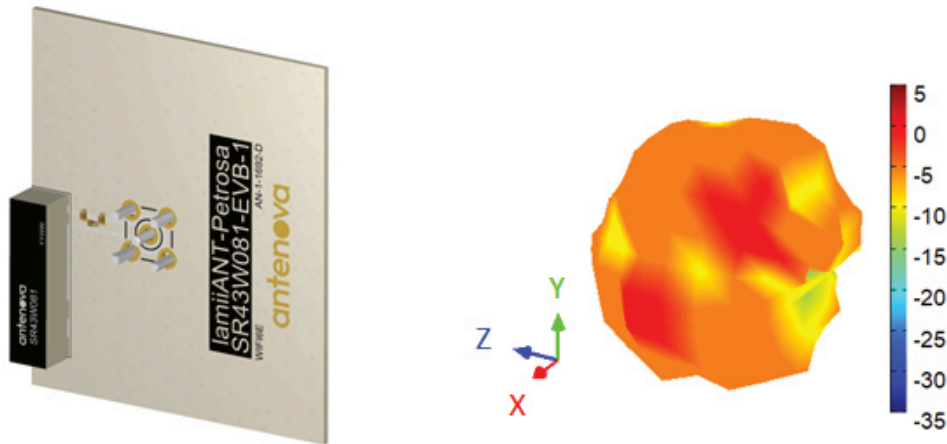

# 7. Antenna dimensions

## 7.1. Dimensions Assembled

Top view

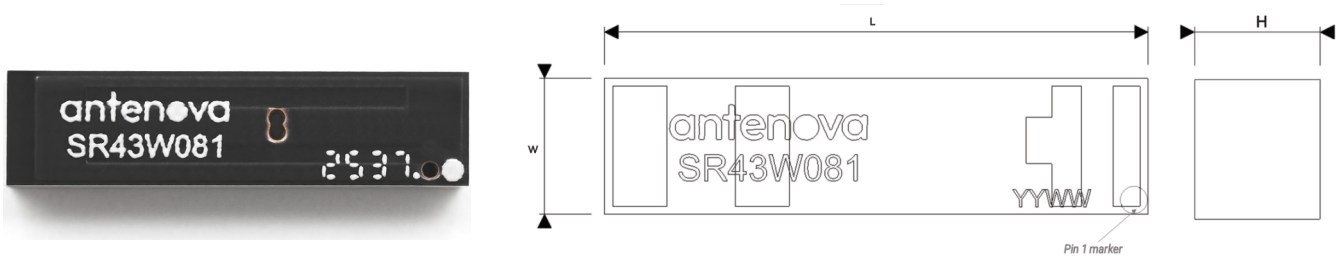

L	W	H
Length	Width	Height
20 ± 0.1	5.0 ± 0.1	5.0 ± 0.2

All dimensions in (mm)

Bottom view

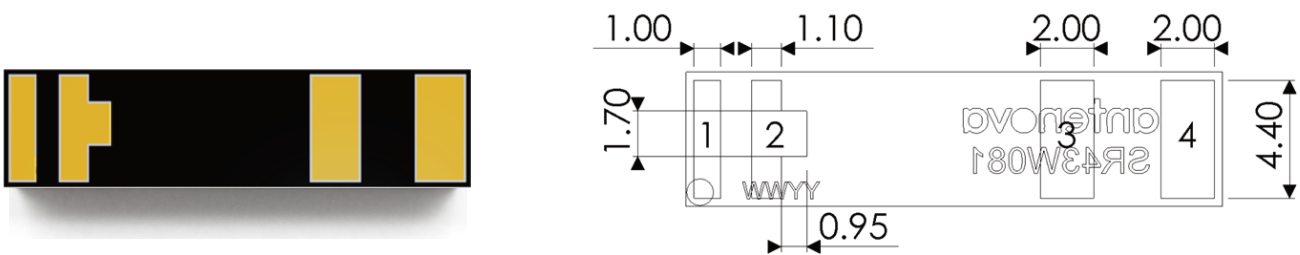

1,2 copper pads are varied by different size (mm)

3,4 copper pads: 2.0 x 4.4 (mm)

## 8. Schematic symbol and pin definition

The circuit symbol for the antenna is shown below. The antenna has four pins with two as functional. All other pins are for mechanical strength.

Pin	Description
2	Feed
1	GND
Others	Not used (Mechanical only)



## 9. Host PCB footprint

The recommended host PCB footprint is below.

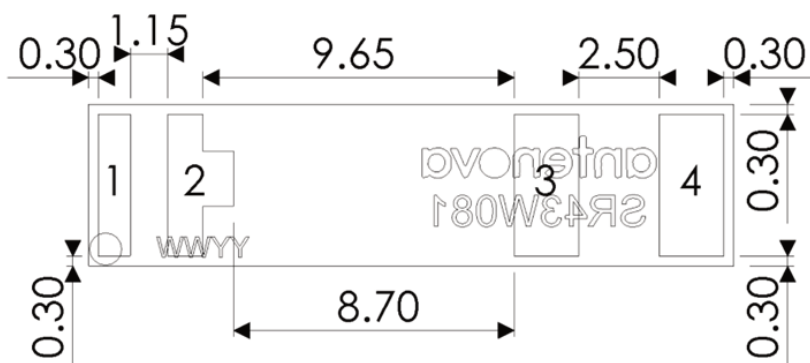

1,2 copper pads are varied by different size (mm)

3,4 copper pads: 2.0 x 4.4 (mm)

## 10. Electrical interface

### 10.1. Transmission line

All transmission lines should be designed to have a characteristic impedance of  $50\Omega$ .

- The length of each transmission lines should be kept to a minimum
- All other parts of the RF system like transceivers, power amplifiers, etc, should also be designed to have a  $50\Omega$  impedance

A co-planar transmission line can be designed using an online transmission line calculator tool, such as:

<https://blog.antenna.com/rf-transmission-line-calculator>

The PCB thickness, copper thickness and substrate dielectric constant are entered, then the tool calculates the transmission line width and gaps on either side of the track to give a  $50\Omega$  impedance.

### 10.2. Matching circuit

The antenna requires a matching circuit that must be optimized for each product. The matching circuit will require up to three components and the following circuit should be designed into the host PCB. Not all components may be required but should be included as a precaution. The matching network should be placed close to the antenna feed to ensure it is optionally effective in tuning the antenna.

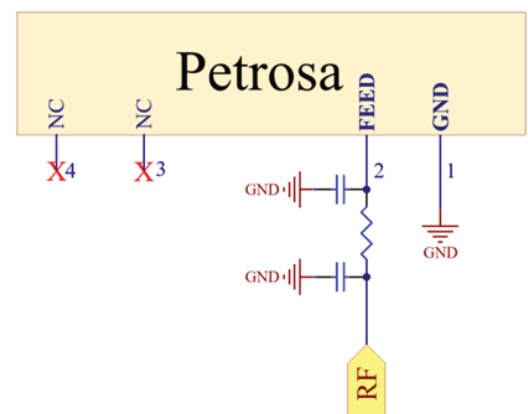

## 11. Antenna integration guide

We recommend the following during the design phase to maximise antenna performance and minimize noise:

- Minimum 4- layer PCB
- Route signals and power internally where possible
- Flood all layers with ground
- Knit ground on all layers together with plenty of vias

Follow placement guidance carefully, in addition Antenova provide technical support to help you through all stages of your design. Register for an account on <https://ask.antenova.com/> to access technical support.

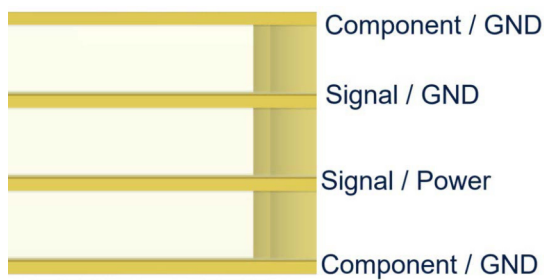

### 11.1. Antenna placement

The antenna requires only top layer clearance ideally in one spatial direction in antenna area as shown below.

The Antenova placement tool can be used to advise on antenna placement, see: <https://blog.antenova.com/intelligent-antenna-selection-and-placementtool-antenova>



## 11.2. Host PCB layout

The host PCB must be designed using the PCB footprint shown with the correct position. An example of the PCB layout shows the antenna footprint. Please note the dimensions given for the separation between the pads and the ground plane. Also note that pad layout on the bottom of the antenna, these dimensions are critical for the performance of the antenna.

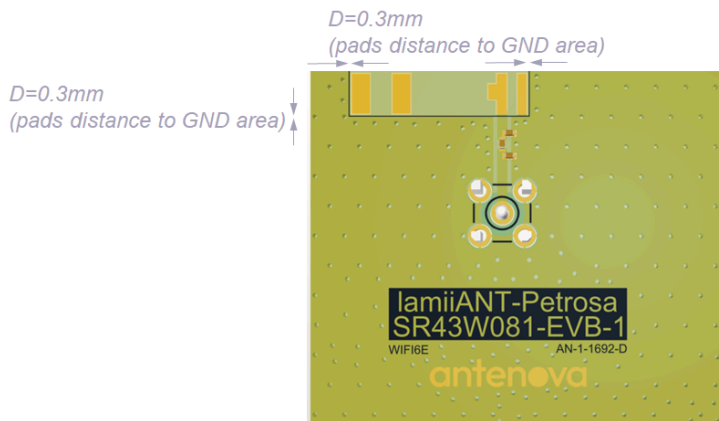

### 11.3. Host PCB clearance

1. The area under the antenna should be free from any copper traces. There may be groundplane on bottom layer (0.8mm FR-4) or bottom two layers (1.6mm FR4). Refer to image below for further detail.
2. The area directly below the antenna should be free from any copper traces. Ground plane may be used as shown in Table X.

**Table X**

4-Layer FR-4	0.8mm	1.6m
Top Layer	No	No
Layer 2	No	No
Layer 3	No	Yes
Bottom Layer	Yes	Yes

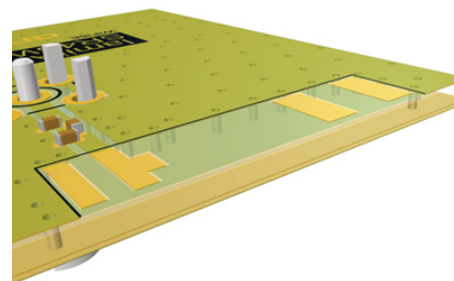
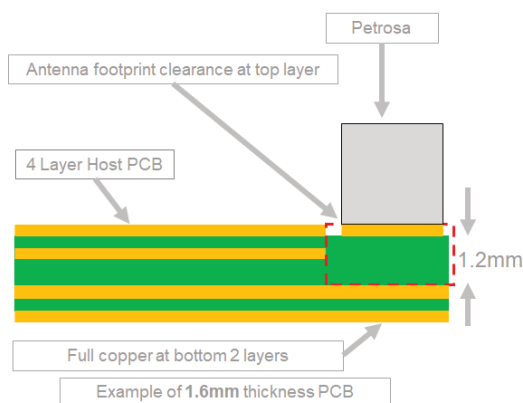
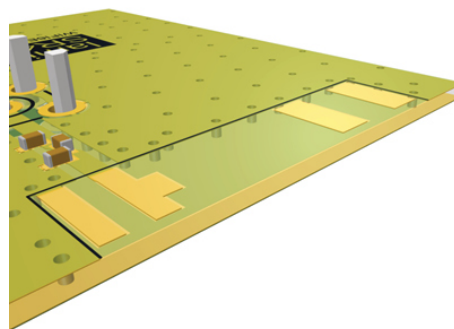
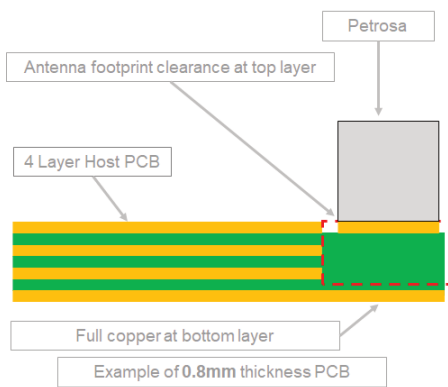

## 12. Reference board

A reference board is used for evaluating the antenna SR43W081 and it includes an SMA female connector. (Part number SR43W081-EVB-1)

To order a reference board  
Please see [antenna.com](http://antenna.com)



### 12.1. Reference board matching circuit

Designator	Type	Value	Description
C1	Capacitor	0.2 pF	Murata GJM15 series
C2	Not Fitted	Not Fitted	Not Fitted
R1	Resistor	0 ohm	Non-specific (0402)

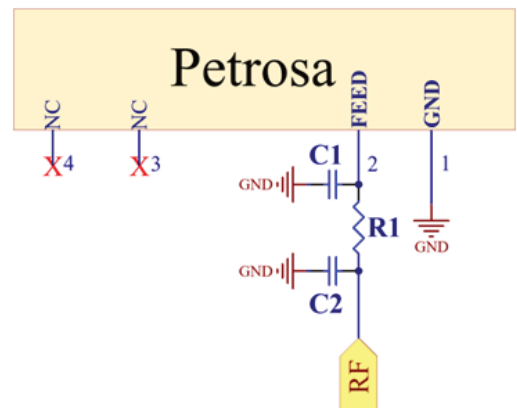

## 13. Soldering

---

This antenna is suitable for lead free soldering. The reflow profile should be adjusted to suit the device, oven and solder paste, while observing the following conditions:

- For leaded soldering, the maximum temperature should not exceed 240 °C.
- For lead free soldering, a maximum temperature of 255 °C for no more than 20 seconds is permitted.
- The antenna should not be exposed to temperatures exceeding 120 °C more than 3 times during the soldering process.

## 14. Hazardous material regulation conformance

---

The antenna has been tested to conform to RoHS and REACH requirements.

A certificate of conformance is available from Antenova's website.

## 15. Packaging

---

### 15.1. Optimal storage conditions

Temperature	-10°C to 40°C
Humidity	Less than 75% RH
Shelf life	24 Months
Storage place	Away from corrosive gas and direct sunlight
Packaging	Reels should be stored in unopened sealed manufacturer's plastic packaging.
MSL level	1

Note: Storage of open reels of antennas is not recommended due to possible oxidization of pads on antennas. If short term storage is necessary, then it is highly recommended that the bag containing the antenna reel is re-sealed and stored in conditions as described in the table above.

The shelf life of the antenna is 2 years provided the factory seal on the package has not been broken.

### 15.2. Tape characteristics

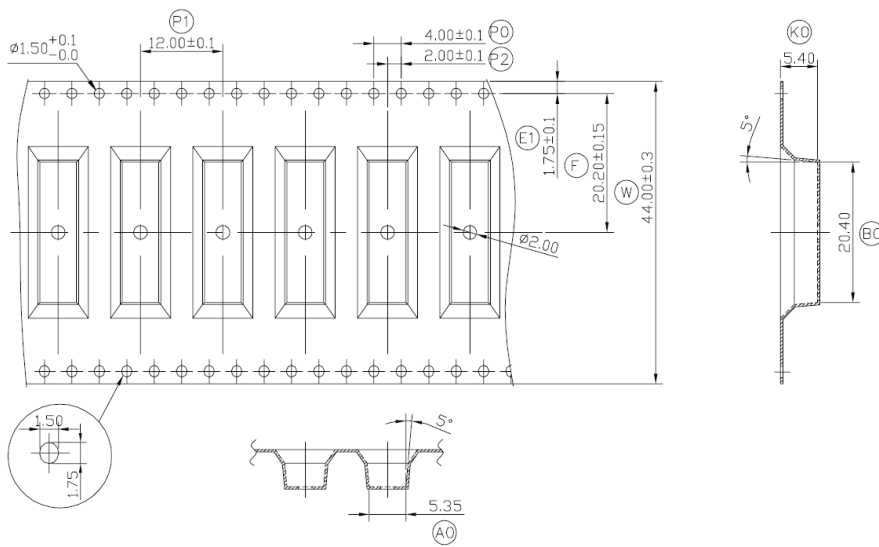

P0	P1	P2	A0	K0	B0
4.00 ± 0.10	12.00 ± 0.10	2.00 ± 0.10	5.35 ± 0.10	5.40 ± 0.10	20.40 ± 0.10

E1	F	W
1.75 ± 0.10	20.20 ± 0.15	44.00 ± 0.30

All dimensions in (mm)

Quantity	Leading space	Trailing space
1000 pcs / reel	30 blank antenna holders	30 blank antenna holders

### 15.3. Reel dimensions

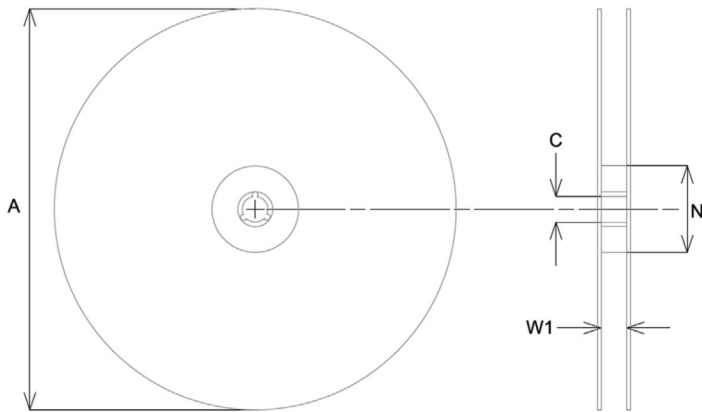

A	C	N	W1
330.0 ± 2.0	13.0 ± 0.5/-0.2	178.0 ± 0.2	44 ± 2.0/-0

All dimensions in (mm)

### 15.4. Box Dimensions

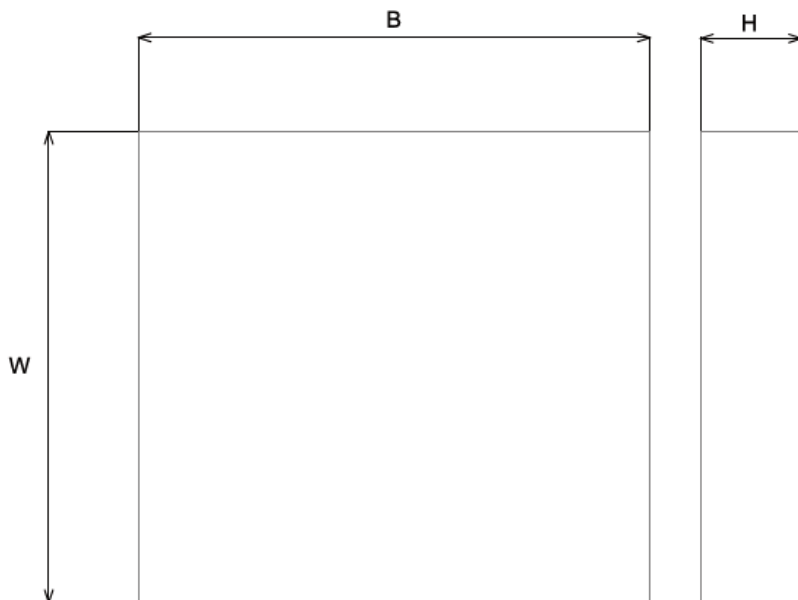

Width (W)	Breadth (B)	Height (H)
350mm	340mm	65mm

### 15.5. Bag properties

Reels are supplied in protective plastic packaging.

### 15.6. Reel label information



### Quality statements

Antenova’s products conform to REACH and RoHS legislation. For our statements regarding these and other quality standards, please see [antenova.com](http://antenova.com).



Antenova reserves all rights to the contents of this document. Antenova gives no warranties based solely on the accuracy or completeness of the contents of this document and reserves the right to make changes to the specifications of the products described herein at any time and without notice.

### Datasheet version

1.10 released 6th March 2026

## Antenna design, integration and test resources

Product designers – the details contained in this datasheet will help you to complete your embedded antenna design. Please follow our technical advice carefully to obtain optimum antenna performance.

We aim to support our customers to create high performance wireless products. You will find a wealth of design resources, calculators and case studies to aid your design on our website.

Antenuova's design laboratories are equipped with the latest antenna design tools and test chambers. We provide antenna design, test and technical integration services to help you complete your design and obtain the required certifications.

If you cannot find the antenna you require in our product range, please contact us to discuss creating a custom antenna to meet your exact requirements.

Share knowledge with RF Experts around the world

ask.antenuova is a global forum for designers and engineers working with wireless technology

[Visit Ask.Antenuova](#)

Visit [antenuova.com](http://antenuova.com)

Order antenna samples and evaluation boards, and read our antenna resources

[Visit antenuova.com](http://antenuova.com)

Request a volume quotation for antennas:

[sales@antenuova.com](mailto:sales@antenuova.com)

+ 44 (0) 23 9400 1023

Global headquarters

Antenuova Ltd, 7 The Briars,  
Waterberry Drive, Waterlooville,  
Hampshire, PO7 7YH